

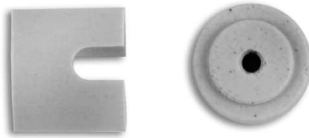

Accessories

▼ IN STOCK ITEMS ▼

Terminal Covers: High Temperature (for use with post terminals)



Individual ceramic terminal covers are designed to protect the operator from exposed terminals. The cover body is slotted to receive two wires and may be installed after wiring has been completed.

Catalog Number	Post Size
CC10-24	10-24 threads
CC10-32	10-32 threads
CC80-32	8-32 threads
CC60-32	6-32 threads

Ceramic Feed Throughs

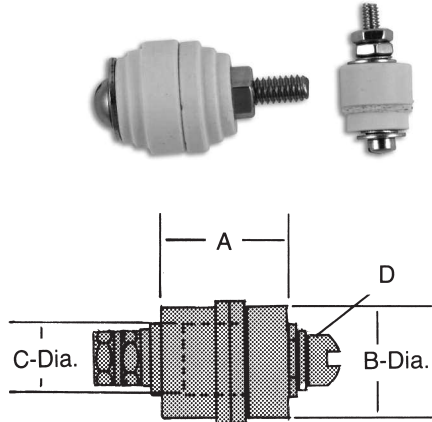

Catalog No.	A-Length	B-Dia	C-Mounting Hole Dia	D-Screw Size
AC2C0042	.505"	.545"	.375"	8-32 x 1 1/4"
AC2C0500	.312"	.375"	.250"	6-32 x 1"
AC2C0101	1.000"	1.000"	.560"	1/4"-20 x 1 3/4"

Each assembly consists of a male and a female ceramic insulator with stainless steel screw with two flat washers, one lockwasher, two hex nuts, and two fiberwashers.

Ceramic bushings without hardware are also available.

Ceramic Insulating Beads: High Temperature



Trade Size	Catalog Number	Dimensions		
		I.D.	O.D.	Length
1	AC2C5000-5	.056"	.110"	.110"
2	AC2C5000-4	.068"	.170"	.170"
3	AC2C5000-3	.092"	.200"	.200"
4	AC2C5000-2	.152"	.260"	.260"
6	AC2C5000-1	.156"	.400"	.400"

Trade Size	Wire Size	Beads/Foot	Beads/Std Package
1	16AWG	134	670
2	14AWG	86	430
3	12AWG	70	350
4	8AWG	54	270
6	8AWG	34	170

Sleeving: Non-Fraying Fiberglass

Temperatures up to 1200°F (650°C) - for abrasion protection and extra electrical insulation.



Natural (tan) Coloring
100 foot spools

Catalog No.	Size	Nom. I.D.	Fits Lead Wire
AC10G0001-17	#17	.047"	#26
AC10G0001-14	#14	.066"	#24
AC10G0001-10	#10	.106"	#20
AC10G0001-8	#8	.133"	#16
AC10G0001-4	#4	.208"	#10

Sleeving: Silicone Rubber Coated Fiberglass

Temperatures up to 428°F (220°C) - for abrasion protection, extra electrical insulation and moisture resistance.



White
100 foot spools

Catalog No.	Size	Nom. I.D.	Fits Lead Wire
AC10S0000-13	#13	.076"	#24
AC10S0000-10	#10	.105"	#20
AC10S0000-8	#8	.133"	#16
AC10S0000-6	#6	.166"	#14
AC10S0000-4	#4	.208"	#10

ACCESSORIES



Accessories

▼ IN STOCK ITEMS ▼

Conduit: High Temperature, Stainless Steel, Flexible Type (for abrasion and flexing protection)



Catalog Number	I.D.	O.D.
C-250	5/32"	1/4"
C-350	1/4"	11/32"
C-375	9/32"	3/8"
C-500	3/8"	15/32"

Cement: High temperature



Terminals: High Temperature Ring Type



Serviceable to 900°F (482°C)
Nickel Plated S.S.

Catalog Number	Awg. Size	Stud
HTR2218-6	22-18	6
HTR2218-8	22-18	8
HTR2218-10	22-18	10
HTR1614-6	16-14	6
HTR1614-8	16-14	8
HTR1614-10	16-14	10
HTR1210-8	12-10	8
HTR1210-10	12-10	10

- This cement insulates electricity but radiates heat. It also resists acids, oils, and temperatures up to 3000°F. This is the same cement Hotwatt uses in electric heating elements and can be used for electric kilns, furnaces, and resistors. The cement hardens into a porcelain-like body by air drying without the use of kilns or injury to the resistant wire.

- Catalog No. C-78 - 1 quart container.

Tape: Glass Cloth (High temperature electrical wiring tape)



- Glass cloth tape no. 27 is a high heat splicing tape composed of a glass cloth locking and an adhesive that thermosets in high application environments. It is a Class B 266°F (130°C) electrical insulation.

- Catalog no. 27 - 1/2" wide x 66' long

ACCESSORIES



Accessories

▼ IN STOCK ITEMS ▼

Wire: High Temperature Hook-up



Features

- The high temperature insulated wires are for use in internal wiring of domestic, commercial, and industrial heating, cooking, and process equipment.
- Wires are suitable for service up to rated voltage in damp and dry applications with wire temperatures up to 250°C (482°F); with intermittent use in ambients as high as 650°F.
- Wires are identical to that used on our own heating elements.
- Available in 100 foot and 250 foot spools.

ACCESSORIES

300 Volt - 250°C Wire

U.L. and C.S.A. rated for 300V/250°C

600 Volt - 250°C Wire

U.L. and C.S.A. rated for 600V/250°C

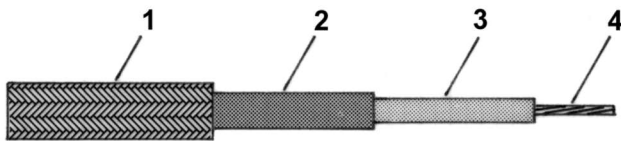

Construction

- 1 Teflon treated fiberglass braid.
- 2 Fiberglass.
- 3 Teflon tape wrap.
- 4 Flexible, stranded nickel conductor.

Construction

- 1 Teflon treated fiberglass braid.
- 2 Teflon tape wrap.
- 3 Flexible, stranded nickel plated copper conductor.

Part No.	Avg. Wire Size	Max. O.D.	Maximum Amp. cap at ambient of:	
			30°C	225°C
9G-N12T-1	12	.165	16.8	8.0
9G-N14T-1	14	.141	12.5	6.0
9G-N16T-1	16	.126	9.2	4.2
9G-N18T-1	18	.110	7.1	3.3
9G-N20T-1	20	.097	5.4	2.4

Part No.	Avg. Wire Size	Max. O.D.	Maximum Amp. cap at ambient of:	
			30°C	225°C
9G-P10T-2	10	.195	35	22.0
9G-P12T-2	12	.168	28	16.2
9G-P14T-2	14	.147	21	12.0
9G-P16T-2	16	.126	15.4	8.7
9G-P18T-2	18	.116	11.9	6.9
9G-P20T-2	20	.105	9.1	4.8



Accessories

▼ IN STOCK ITEMS ▼

Resistance Wire: Nickel Chromium

Features

- Hotwatt's nickel-chromium wire (80ni-20cr) is proven to deliver outstanding performance over extended periods of time and is the same wire we use in our own electrical heating elements.
- Uniformity of resistance.
- Mechanical stability.
- Fine surface finish.
- Consult factory for specifications on other sizes and different alloys which are available. Typically Iron-Chromium-Aluminum alloy, Nickel-Iron Alloy and Thermocouple Alloys.

Round Wire



Catalog Number	AWG Size	Nominal Wire Dia.	Ohms/Ft.
R15	15	.057	.20
R16	16	.051	.25
R17	17	.045	.32
R18	18	.04	.41
R19	19	.036	.50
R20	20	.032	.65
R21	21	.028	.80
R22	22	.025	1.02
R23	23	.023	1.27
R24	24	.02	1.61
R25	25	.018	2.03
R26	26	.016	2.57
R27	27	.014	3.22
R28	28	.013	4.09
R29	29	.011	5.09
R30	30	.01	6.50
R31	31	.009	8.20
R32	32	.008	10.16
R33	33	.007	12.89
R34	34	.006	16.38

Ribbon Wire



Catalog Number	AWG Size	Nominal Wire Dia.	Ohms/Ft.
RR-1	.0015"	1/64"	22.75
RR-2	.002"	1/64"	17.36
RR-3	.0031"	1/64"	11.20
RR-4	.0035"	1/64"	9.99
RR-5	.004"	1/64"	8.68
RR-6	.0045"	1/64"	7.12
RR-7	.005"	1/64"	6.95
RR-8	.0056"	1/64"	6.20
RR-9	.0063"	1/64"	5.51
RR-10	.002"	1/32"	9.83
RR-11	.0031"	1/32"	5.60
RR-12	.0035"	1/32"	4.96
RR-13	.004"	1/32"	4.34
RR-14	.0045"	1/32"	3.86
RR-15	.005"	1/32"	3.47
RR-16	.0063"	1/32"	2.76
RR-17	.0031"	1/16"	3.17
RR-18	.0035"	1/16"	2.81
RR-19	.004"	1/16"	2.46
RR-20	.0045"	1/16"	1.93
RR-21	.005"	1/16"	1.74
RR-22	.0056"	1/16"	1.55
RR-23	.0063"	1/16"	1.38
RR-25	.0031"	3/32"	2.11
RR-26	.0035"	3/32"	1.87
RR-27	.0045"	3/32"	1.46
RR-28	.0063"	3/32"	.91
RR-29	.0031"	1/8"	1.59
RR-30	.0035"	1/8"	1.40
RR-31	.004"	1/8"	1.23
RR-32	.0045"	1/8"	1.09
RR-33	.005"	1/8"	.98
RR-34	.0056"	1/8"	.88
RR-35	.0031"	3/16"	.88
RR-36	.0035"	3/16"	.78
RR-37	.004"	3/16"	.68
RR-38	.0045"	3/16"	.60
RR-39	.005"	3/16"	.54

- Hotwatt will also supply resistance wire in coil form to your specifications. Consult factory for details.
- Refer to current carrying capacity tables on page 170.



Accessories

▼ IN STOCK ITEMS ▼

Hot Lube

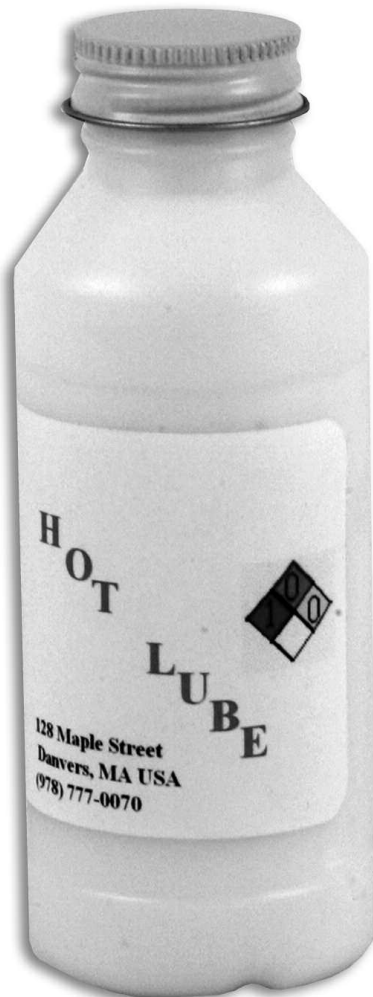

- Hot Lube can greatly reduce heater-to-bore seizure when properly applied.
- Improves thermal conductivity. Heat transfers more quickly from heater to part being heated when Hot Lube is used.
- Increased heater life. Tighter fit made practical with use of Hot Lube.
- Not electrically conductive.
- Hot Lube solution is not considered hazardous.
- Easy to use.
- Withstands temperatures to 1600°F (875°C)

Available from stock, call you nearest Hotwatt Distributor.

Ordering Information:

4 ounce container catalog no. - [ACHOTLUBE044](#)

Directions

- Heater surface should be clean and dry.
- Shake Hot Lube well before use.
- Brush on a light uniform coat of Hot Lub.
- Allow to air dry for 20 minutes or oven dry at low temperature (140°F maximum).

CAUTION: DO NOT ALLOW HOT LUBE TO COME IN TO CONTACT WITH LEAD WIRES OR LEAD END OF HEATER.